

Data sheet

DE40 Differential pressure transmitter

This differential pressure transmitter is suitable for measuring over-pressure, under-pressure and differential pressure in basically neutral fluids and gases. It is suitable for all measuring tasks in industrial or sanitary sectors.

Typical applications are:

- Differential pressure measurements between the supply and return on heating systems.
- Monitoring of filters, fans and compressors.

Design and mode of operation

The differential pressure transmitters of this series are equipped with a non-sensitive ceramic pressure measuring cell.

The measuring pressure acts on the ceramic membrane which in turn deforms. There is a DMS bridge attached to the membrane whose resistance value changes in proportion to the level of deformation.

The electronics integrated into the transmitter housing convert this resistance change into the standard signals 0...10V and/or 4...20mA.

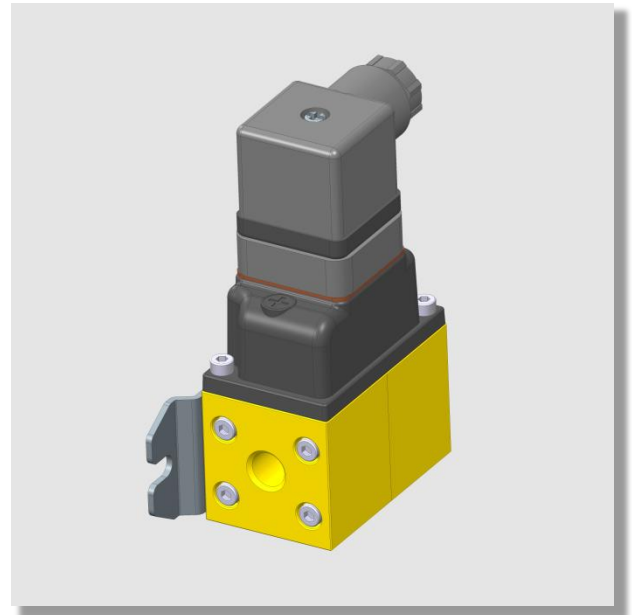

Important features

- Very versatile
- Small and compact
- Variable connection technology

Functional Schematic

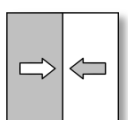
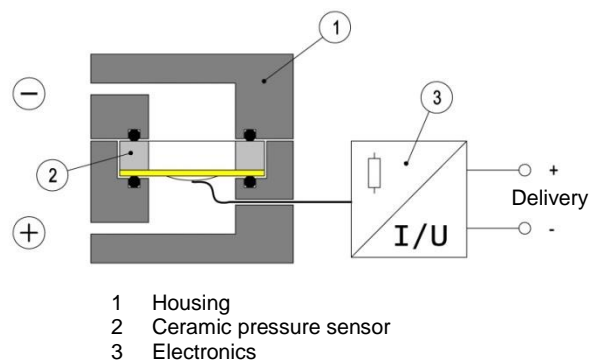

Technical data

Measuring Range	bar	0 ...	2	4	6	10
One-sided max. pressure	bar	(+) side	10	21	21	25
	bar	(-) side	5	15	15	25
Static operating pressure	bar	max.	21	21	21	45
Nominal pressure	bar		16	16	16	45
Characteristic curve deviation ¹	%FS	max.	≤ 1	≤ 1	≤ 1	≤ 1

General points

Admissible ambient temperature	-20 ... +80 °C
Admissible media temperature	-20 ... +80 °C (for non-freezing media)
Admissible storage temperature	-20 ... +90 °C
Enclosure protection class	IP65 as per DIN EN 60529

Electrical data

Rated Voltage	24 VDC
Allowed operating voltage U_b	24 VDC ±20% (19.2 ... 28.8 VDC)
Electrical connection type	Three-conductor
Output signal	4 ... 20 mA 0 ... 10 V
Allowed load at rated voltage	$R_L=700 \Omega$ $R_L=2 k\Omega$
Characteristic curve	linear
Power consumption	< 1.5 W

Ports

Process connection	1/8" Cutting ring screw connection in brass, CrNi steel for 6 or 8mm pipe 1/8" pneumatic plug connector for 6 or 8 mm hose
Electrical connection	Plug connector DIN EN 175301-803A M12 plug (5-pin, male)

Materials

Casing lid	Cast zinc
Media-contacting material ²	Brass CrNi steel 1.4305
O-rings	EPDM (with KTW-approval) FKM (only in combination with the CrNi-steel housing)
Pressure measuring cell	Ceramic

Assembly

2 attachment boreholes on the housing
Wall mounting plate
Any installation position

¹ Non-linearity and hysteresis at 25°C
² Depending on the selected housing

Dimensional drawings (all dimensions in mm unless otherwise specified)

Process connections and plug connector can be freely combined acc to order code. As not all combination can be shown, here are examples of some typical combinations.

Process connection on the side (rectangular connector DIN EN 175301-803 A)

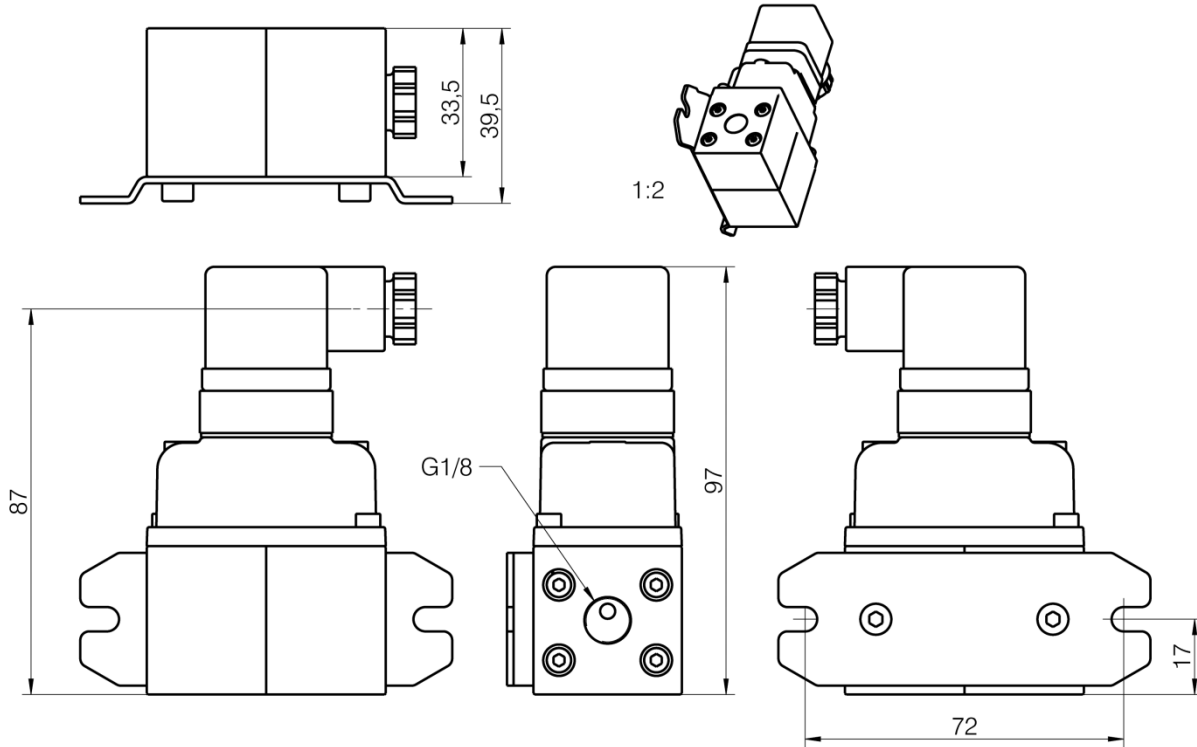

Process connection below

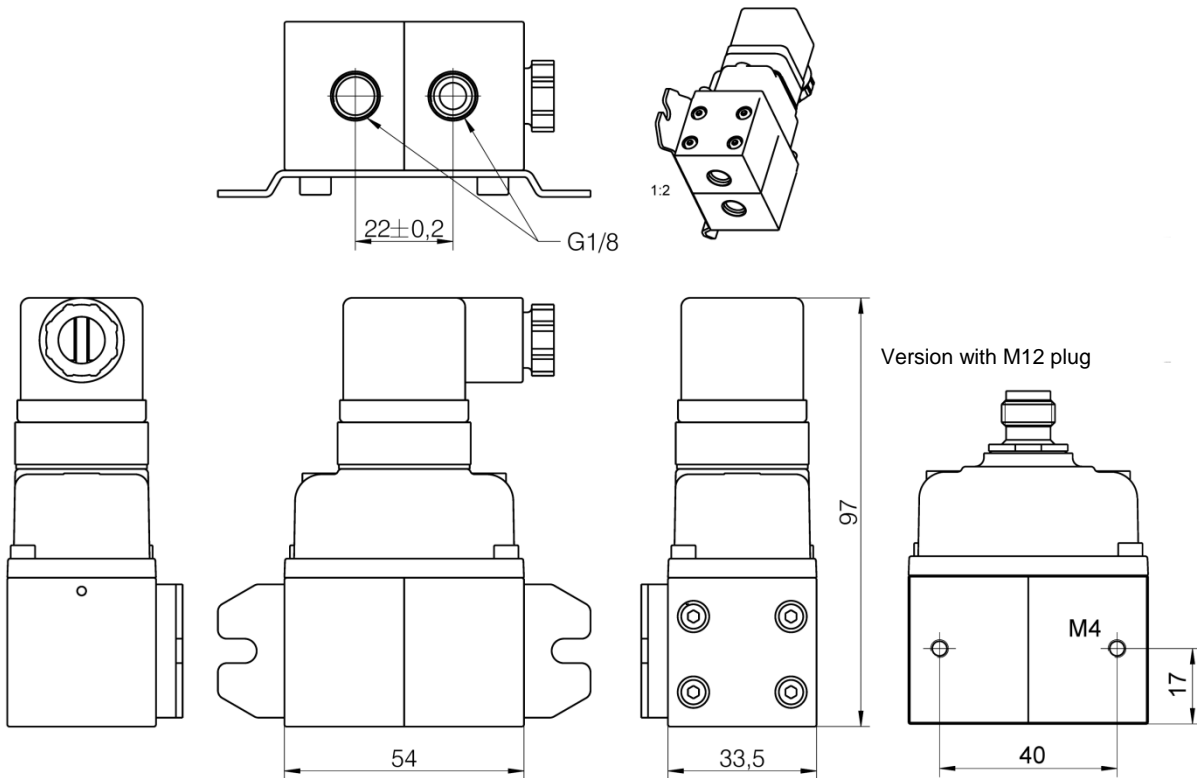

Electrical connection

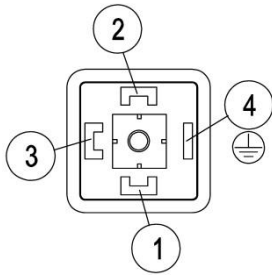

DIN EN 175301-803A

- 1 Delivery +Sig
- 2 Supply - U_b
- 3 Supply +U_b
- 4 Functional earth

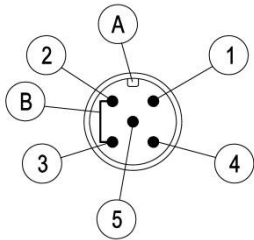
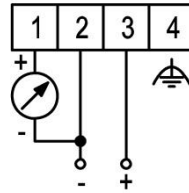

M12 connector (male)

- 1 Supply +U_b
 - 2 Delivery -Sig
 - 3 Supply - U_b
 - 4 Delivery +Sig
 - 5 Functional earth
- A Coding
B Bridge

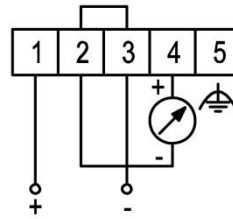

Order Codes

Digital differential pressure transmitter

Type DE40

			0			A			0	0	
--	--	--	---	--	--	---	--	--	---	---	--

Measuring Range

- 0 ... 2 bar> 4 5
- 0 ... 4 bar> 0 5
- 0 ... 6 bar> 0 6
- 0 ... 10 bar> 0 7

Design of the measuring system

- Pressure chamber brass (pressure connection below)> C
- Pressure chamber brass (pressure connection axial side)> N
- Pressure chamber stainless steel (1.4305) (pressure connection below)> W

Pressure connection

- Inner thread G 1/8> 0 0
- Pneumatic plug connector for 6/4 mm hose> P 6
- Pneumatic plug connector for 8/6 mm hose> P 8
- Cutting ring screw connection in brass for 6 mm pipe> 2 8
- Cutting ring screw connection in brass for 8 mm pipe> 2 9

Electrical output signal

- 0 – 10 V DC 3-wire (STANDARD)> C
- 4 – 20 mA 3-wire (STANDARD)> P

Operating voltage

- 24 V DC (+/- 20%)> A

Electrical connection

- Plug connector DIN EN 175301-803 A (STANDARD)> H
- M12 plug> M

Assembly option

- Standard (attachment boreholes)> 0
- Wall mounting> W